

Instructions

Tektronix

**SD-14 Opt 01
Sampling Head**

063-2011-01

Instrument Serial Numbers

Each instrument manufactured by Tektronix has a serial number on a panel insert or tag, or stamped on the chassis. The first letter in the serial number designates the country of manufacture. The last five digits of the serial number are assigned sequentially and are unique to each instrument. Those manufactured in the United States have six unique digits. The country of manufacture is identified as follows:

B010000	Tektronix, Inc., Beaverton, Oregon, USA
E200000	Tektronix United Kingdom, Ltd., London
J300000	Sony/Tektronix, Japan
H700000	Tektronix Holland, NV, Heerenveen, The Netherlands

Instruments manufactured for Tektronix by external vendors outside the United States are assigned a two digit alpha code to identify the country of manufacture (e.g., JP for Japan, HK for Hong Kong, IL for Israel, etc.).

Tektronix, Inc., P.O. Box 500, Beaverton, OR 97077

Printed in U.S.A.

Copyright © Tektronix, Inc., 1994. All rights reserved. Tektronix products are covered by U.S. and foreign patents, issued and pending. The following are registered trademarks: TEKTRONIX, TEK, TEKPROBE, and SCOPE-MOBILE.

WARRANTY

Tektronix warrants that this product will be free from defects in materials and workmanship for a period of one (1) year from the date of shipment. If any such product proves defective during this warranty period, Tektronix, at its option, either will repair the defective product without charge for parts and labor, or will provide a replacement in exchange for the defective product.

In order to obtain service under this warranty, Customer must notify Tektronix of the defect before the expiration of the warranty period and make suitable arrangements for the performance of service. Customer shall be responsible for packaging and shipping the defective product to the service center designated by Tektronix, with shipping charges prepaid. Tektronix shall pay for the return of the product to Customer if the shipment is to a location within the country in which the Tektronix service center is located. Customer shall be responsible for paying all shipping charges, duties, taxes, and any other charges for products returned to any other locations.

This warranty shall not apply to any defect, failure or damage caused by improper use or improper or inadequate maintenance and care. Tektronix shall not be obligated to furnish service under this warranty a) to repair damage resulting from attempts by personnel other than Tektronix representatives to install, repair or service the product; b) to repair damage resulting from improper use or connection to incompatible equipment; or c) to service a product that has been modified or integrated with other products when the effect of such modification or integration increases the time or difficulty of servicing the product.

THIS WARRANTY IS GIVEN BY TEKTRONIX WITH RESPECT TO THIS PRODUCT IN LIEU OF ANY OTHER WARRANTIES, EXPRESSED OR IMPLIED. TEKTRONIX AND ITS VENDORS DISCLAIM ANY IMPLIED WARRANTIES OF MERCHANTABILITY OR FITNESS FOR A PARTICULAR PURPOSE. TEKTRONIX' RESPONSIBILITY TO REPAIR OR REPLACE DEFECTIVE PRODUCTS IS THE SOLE AND EXCLUSIVE REMEDY PROVIDED TO THE CUSTOMER FOR BREACH OF THIS WARRANTY. TEKTRONIX AND ITS VENDORS WILL NOT BE LIABLE FOR ANY INDIRECT, SPECIAL, INCIDENTAL, OR CONSEQUENTIAL DAMAGES IRRESPECTIVE OF WHETHER TEKTRONIX OR THE VENDOR HAS ADVANCE NOTICE OF THE POSSIBILITY OF SUCH DAMAGES.

Product Description

The SD-14 Opt 01 is a variation on the standard SD-14 Probe Sampling Head, that features the following modifications.

- Probe tip length extended 0.040" (1.0mm)
- Ground barrel threaded 10-40 at top
- Additional custom accessories: Probe to etched circuit board (ECB) adapters, Probe to SMB adapters

The SD-14 Opt 01 is used with the 11801 family of Digital Sampling Oscilloscopes or the CSA803 family of Communications Signal Analyzers. The tip design will accommodate all of the standard accessories provided for the standard SD-14 4mm Probe Tip size.

For more information on the SD-14 Opt 01 that is not specific to this Mod, refer to the SD-14 User Manual (070-8286-01).

NOTE. *The Probe to ECB Adapter and the Probe to SMB Adapter can only be used with the SD-14 Opt 01 probes. Do not attempt to use them with the standard SD-14 probes.*

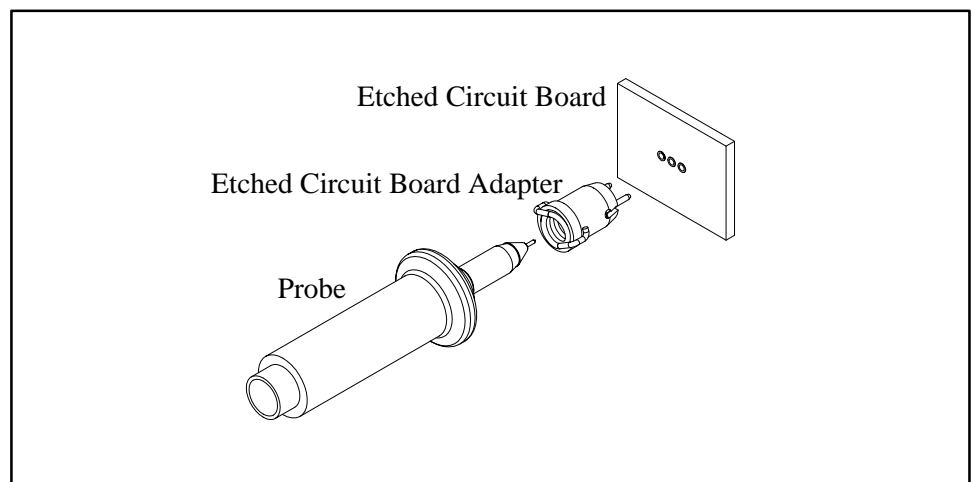

Figure 1: Probe to Etched Circuit Board Adapter

The Probe to Etched Circuit Board (ECB) Adapter is intended to provide a solid mating of the probe tip to a ground-signal-ground ECB pattern. Adjacent pin spacing is 0.075 (0.95mm). The center signal conductor of the probe protrudes

through this adapter and serves as the signal carrying member of the probe and adapter assembly.

The adapter is installed onto the probe tip by gently twisting it counter-clockwise while simultaneously pushing it onto the barrel until it stops. It may be removed by twisting it counter-clockwise while pulling it off.

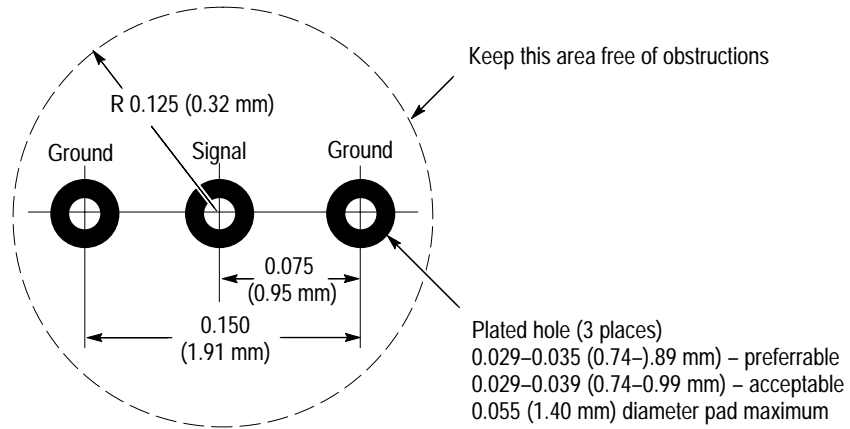

Figure 2: Required ECB Mating Pattern

To test an ECB pattern, align the ground-signal-ground leads to the hole pattern in the ECB, and gently push the probe straight into the ECB until it stops.



CAUTION. To avoid damage to the probe tip,

Do not apply excessive side force to the probe

Maintain the probe at a right angle (90 degree) to the ECB.

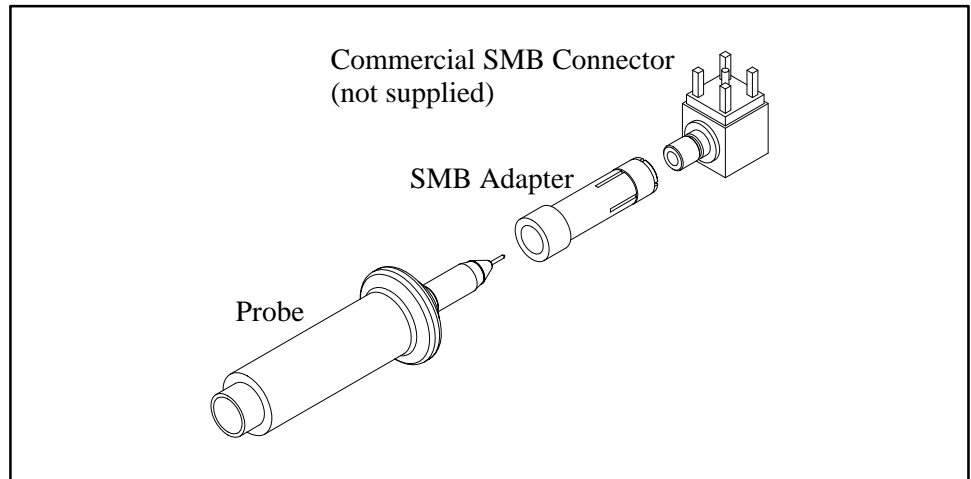

Figure 3: Probe to SMB Adapter

The Probe to SMB adapter is intended to provide a solid mating of the probe tip to an SMB jack coaxial connector. It is a coaxial adapter that is equipped with a probe socket on one side, and a SMB plug on the other side. One type of application is illustrated above, where a right angle SMB jack to ECB connector is used to mate the probe and the to the ECB.

The required ECB pattern depends on the type of SMB jack to ECB adapter used, as there are several available commercially. The following list should serve as a guideline to selecting the proper connector for your application:

Application	Manufacturer	Manufacturer's Part Number
Right angle ECB Mount	E. F. Johnson	131-1701-371
Straight ECB Mount	E. F. Johnson	131-3701-201
ECB End Launch (0.062 board)	E. F. Johnson	131-3701-801

Use care when placing right angle connectors with regard to both the direction the probe extends outward, and also the vertical clearance of the probe to the board. Many SMB right angle connectors are very low profile and do not allow the probe to extend over a usable area of the ECB.

The threaded adapter is installed onto the probe tip by gently twisting it clockwise onto the barrel until it stops. It may be remove by twisting it counter-clockwise. The SMB connection is then made by pushing the connectors together until a snap is felt.



CAUTION. To avoid damage to the probe tip, thread the SMB adapter to the probe before making connection to the SMB connector. Likewise, disconnect the SMB before removing the SMB adapter from the probe.

To disconnect the SMB connector, simply pull on the probe. The adapter will stay with the probe.



CAUTION. Pull only on the probe body. Do not pull on the probe cable, as damage may result to the probe.

Specifications

The specifications listed below pertain only to the addition of Opt 01 to the SD-14. Refer to the SD-14 User Manual (070-8286-01) for any information not listed here.

- Probe Input Impedance: 100K ohm typical
0.550pF typical
- Field Replaceable Unit: 657-0097-50
- Standard Accessories: Probe Etched-Circuit-Board Adapter
Replace with 020-2081-00
(5 ea)
Probe to SMB Adapter
Replace with 020-2082-00
(5 ea)



CAUTION. The SD-14 User and Service Manuals call out the use of a Calibration Fixture, 013-0271-00. The SD-14 Opt 01 must be tested only with an updated version of this fixture, Part number 013-0271-01. The updated version of this fixture remains compatible with the standard SD-14.
